

A

B

C

D

E

F

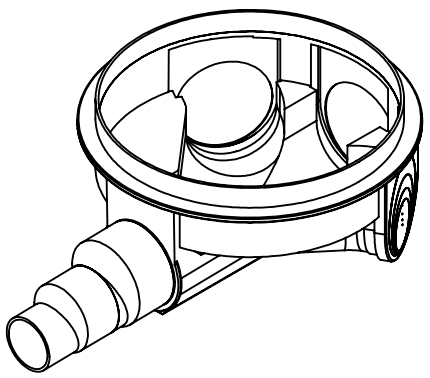
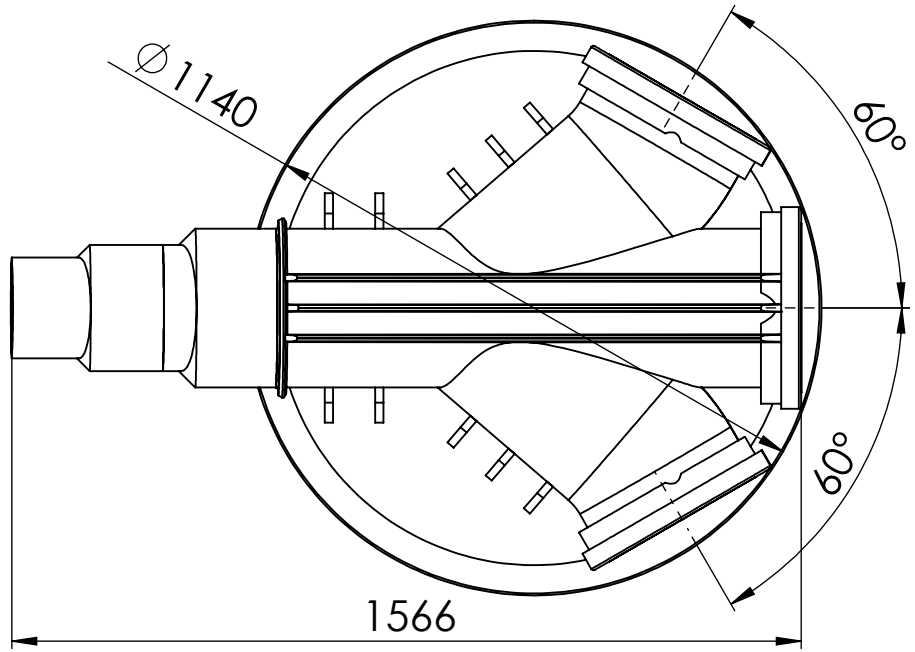
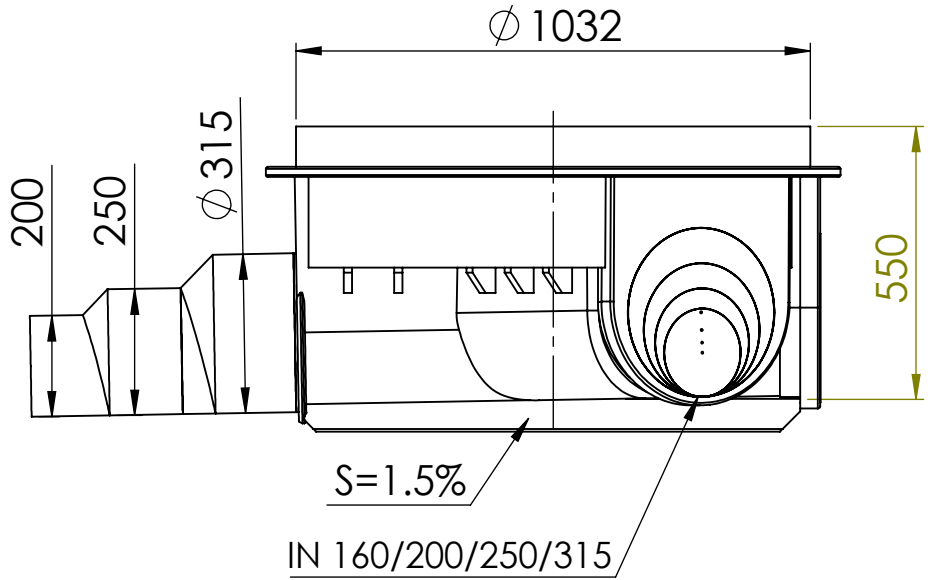

UNLESS OTHERWISE SPECIFIED:
 DIMENSIONS ARE IN MILLIMETERS
 SURFACE FINISH: N8
 TOLERANCES: +/-2%

חופית קיבוץ כנרת
 ד.ב. עמק הירדן 15118
 tel.+972-4-6759530/1/2 F.+972-4-6759518



בסיס קוטר 100 גובה 3,55 כניסות 315"

	NAME	SIGN.	DATE	REV.
DRAWN	דרור		1/29/2015	B
CHK'D				
APPV'D				
Q.A				

FILE NAME:

MATERIAL: **PE:LLDPE**
 FINISH:
 Remark:

DWG. NO. **0207-3B10512H**
 CAT. NO.