

Rev.	Name	Description	Date	ECO No.
B	GIL HASSON	INLET/OUTLET CHANGE	04.10.21	ECO021
C	GIL HASSON	ADD STENGTHEN LEGS	28.11.23	EC23000057

OUTLET	INLET	CAT. NO.
None	None	0213-GS109H
110 (4")	110 (4")	0213-GS1094H
160 (6")	160 (6")	0213-GS1096H
200 (8")	200 (8")	0213-GS1098H

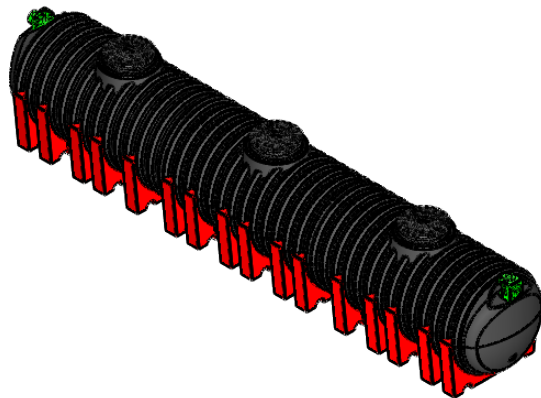
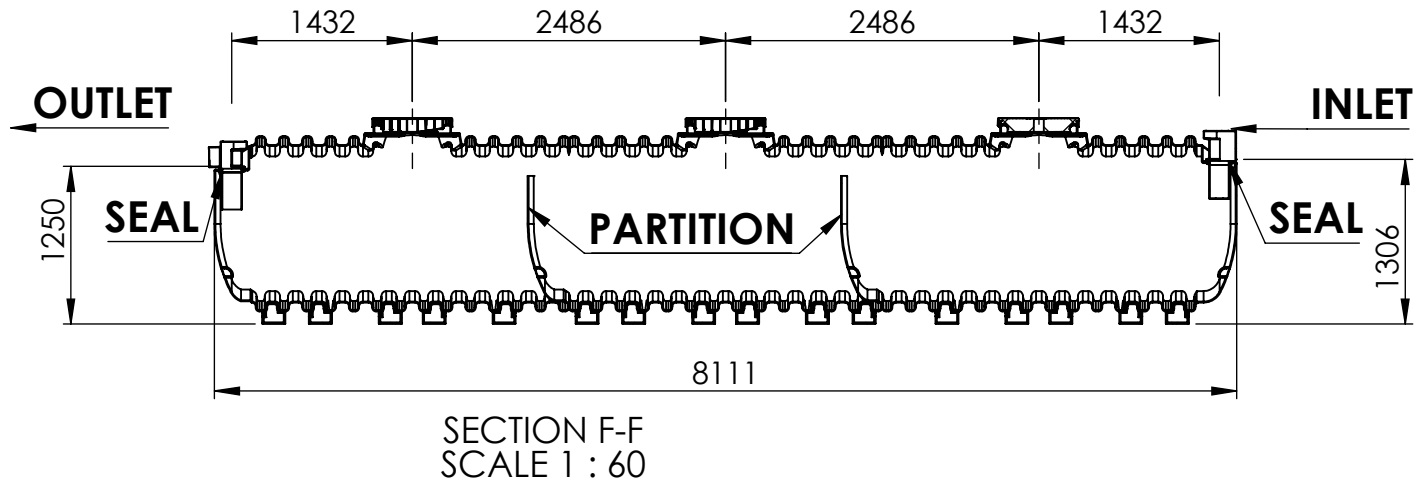
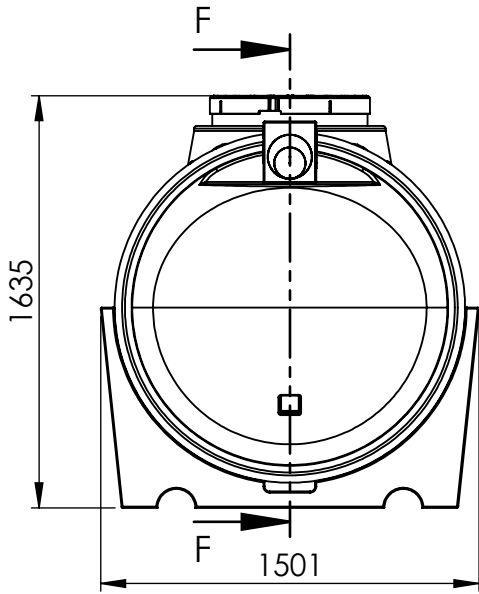

UNLESS OTHERWISE SPECIFIED:
 DIMENSIONS ARE IN MILLIMETERS
 SURFACE FINISH: N8
 TOLERANCES: +/-2%

Huliot[®] Hofit By Huliot Group Ltd.
 Kibbutz Kinneret, Jordan Valley, 1511800 ISRAEL
 tel.+972-4-6759530 | info@hofit.com | www.hofit.com

	NAME	SIGN.	DATE	REV.
DRAWN	Gil Hasson		30/11/2023	C
CHK'D				
APPV'D				

GREASE SEP. 10900L, ON.GR

FILE NAME: 0213-GS109.H

MATERIAL: PE	FINISH: N8	Weight [kg]:
-----------------	---------------	--------------

CAT. NO.: SEE TAB
 DWG. NO.: 0213-GS109.H-E