

Rev.	Name	Description	Date	ECO No.
B	GIL HASSON	INLET/OUTLET CHANGE	04.10.21	ECO021
C	GIL HASSON	ADD STENGTHEN LEGS	28.11.23	EC23000057
D	GIL HASSON	ADD STENGTHEN LEGS	28/08/24	EC24000045

OUTLET	INLET	CAT. NO.
None	None	0213-GS91H
110 (4")	110 (4")	0213-GS914H
160 (6")	160 (6")	0213-GS916H
200 (8")	200 (8")	0213-GS918H

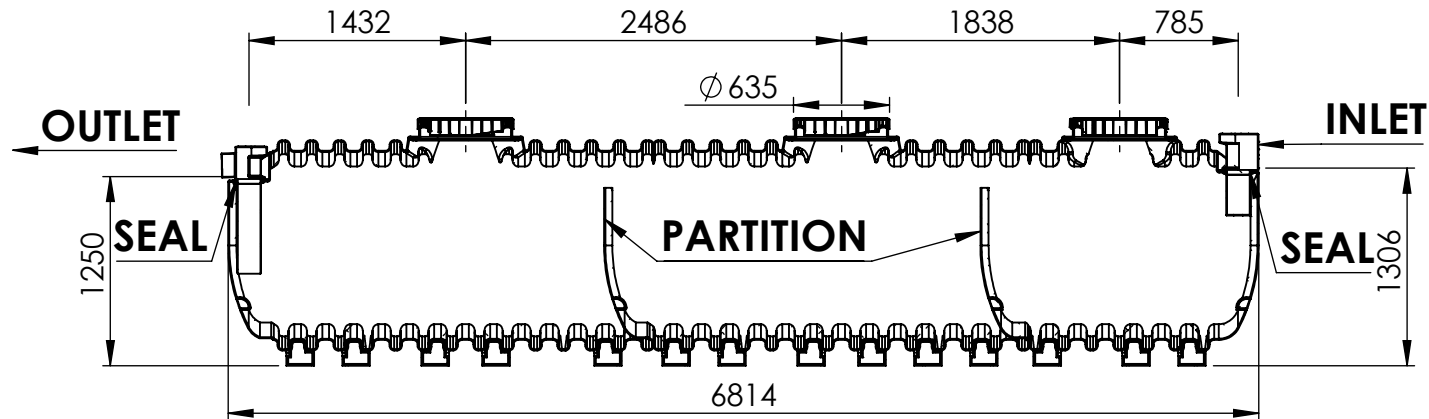

SECTION F-F
SCALE 1 : 50

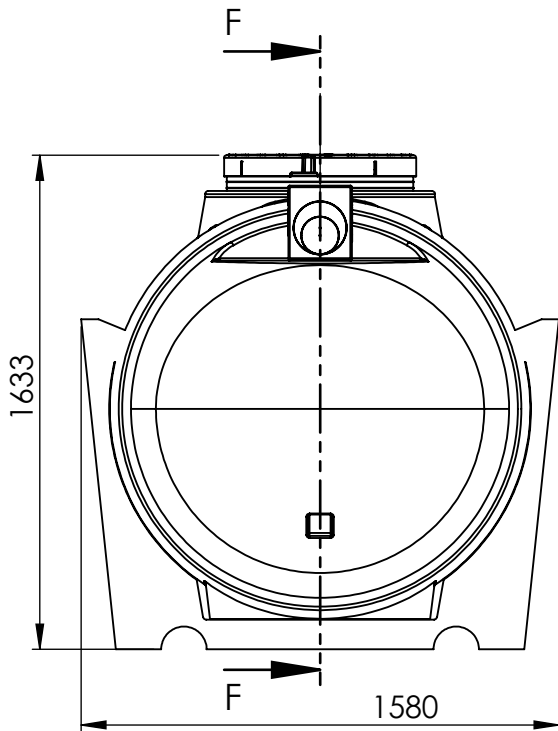
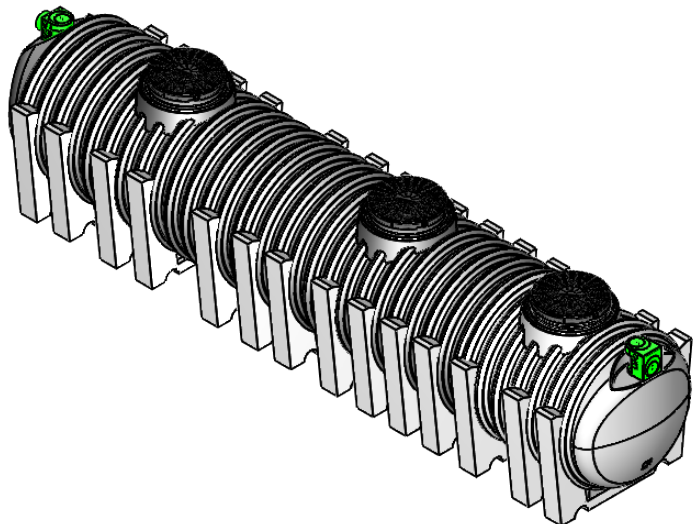

UNLESS OTHERWISE SPECIFIED:
DIMENSIONS ARE IN MILLIMETERS
SURFACE FINISH: N8
TOLERANCES: +/-2%

Huliot® Hofit By Huliot Group Ltd.
Kibbutz Kinneret, Jordan Valley, 1511800 ISRAEL
tel.+972-4-6759530 | info@hofit.com | www.hofit.com

	NAME	SIGN.	DATE	REV.
DRAWN	Gil Hasson		28/08/2024	D
CHK'D				
APPV'D				

**9100L GREASE SEPERATOR OVERGROUND
INSTALLATION**

FILE NAME: 0213-GS91.H

MATERIAL: PE
FINISH: Weight [kg]:

CAT. NO.: SEE TAB
DWG. NO.: 0213-GS91.H-E